

Scalable Building Automation with KMDigital Controls



19476 Industrial Drive, New Paris, IN 46553, U.S.A.

Telephone: 877.444.5622 (574.831.5250)

Fax: 574.831.5252

Web: www.kmccontrols.com

Email: info@kmccontrols.com

"building your comfort zone" is a trademark
and KMDigital®, NetSensor®, NetView®,
WebLite®, and WinControl® are all
registered trademarks of KMC Controls, Inc.
All other products or name brands mentioned
are trademarks of their respective companies.

© 2006 KMC Controls, Inc. SB-042A 10/06



Stand-Alone

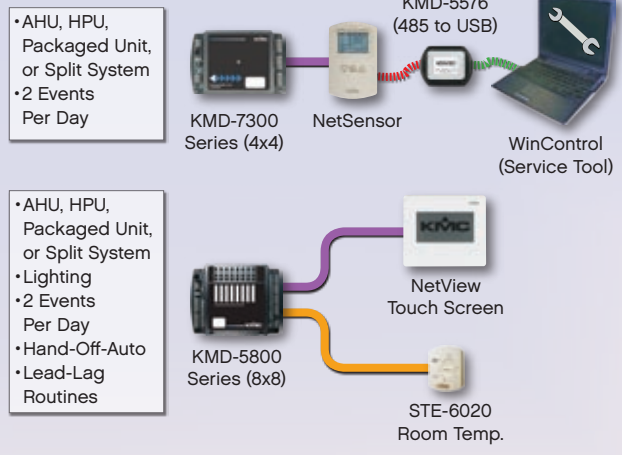

- ### Features at Each KMC Controller
- Peer-to-Peer Communication
 - Passwords
 - PID Loops
 - Programming
 - System Groups
 - Weekly Schedules
 - Annual Routines
 - Runtime Logs
 - Trend Logs
 - Alarms
- (Some features may only be viewable or usable through a service tool)



- ### Connection Designators
- (Dashed lines = temporary connections)
- EIA-485 (formerly RS-485) MS/TP
 - Ethernet TCP/IP
 - General Wiring to Terminals
 - KMC Modular Cables/Connectors
 - Modem/EIA-232 (formerly RS-232)
 - USB

Small Building

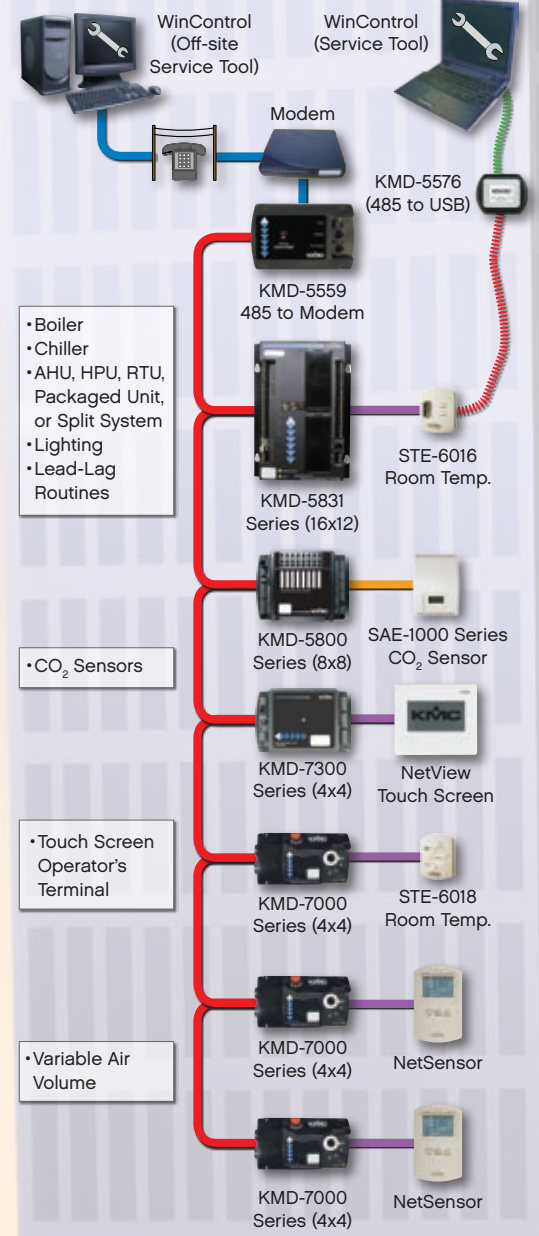

Medium Building

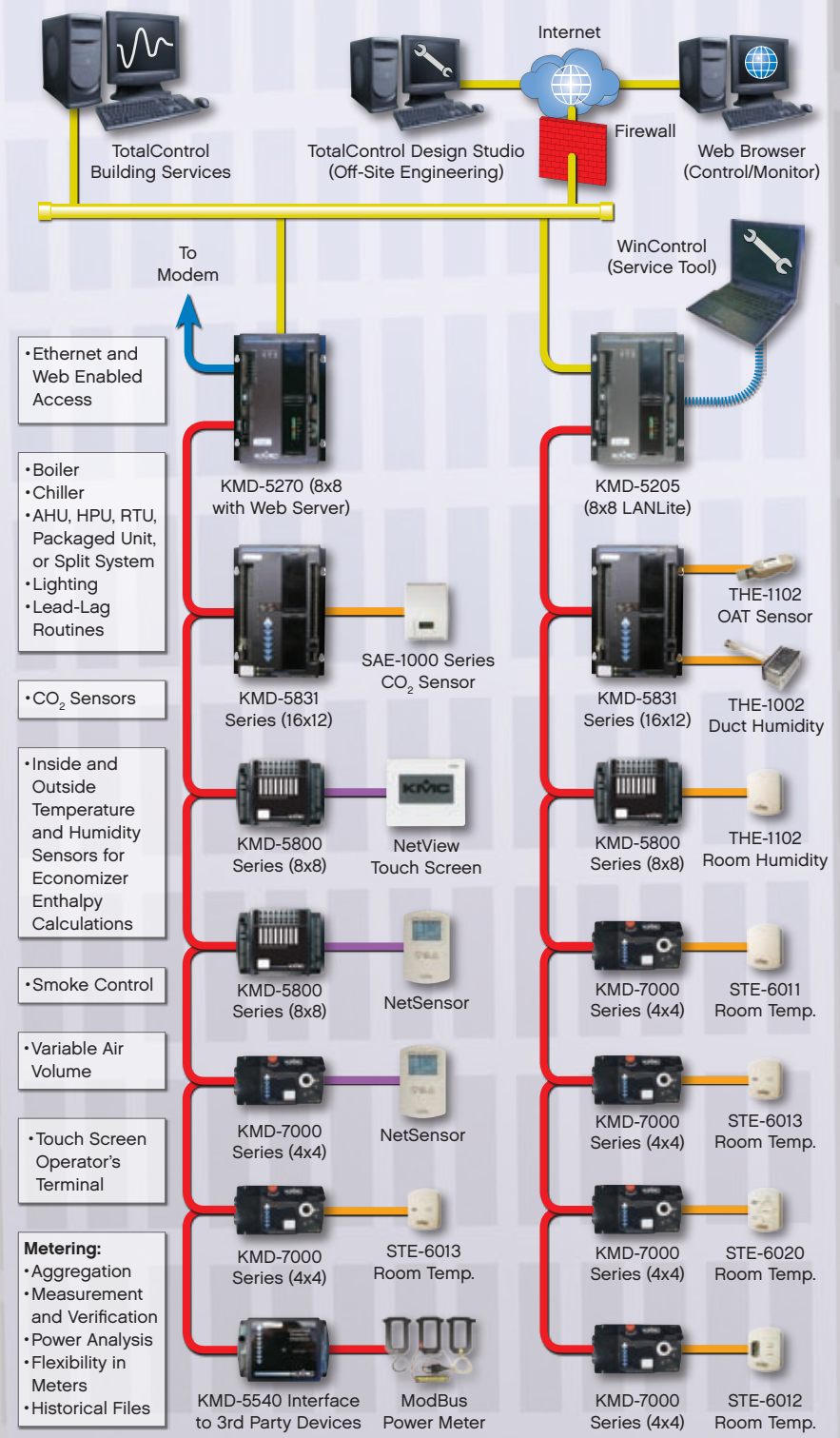

Large or Multiple Buildings

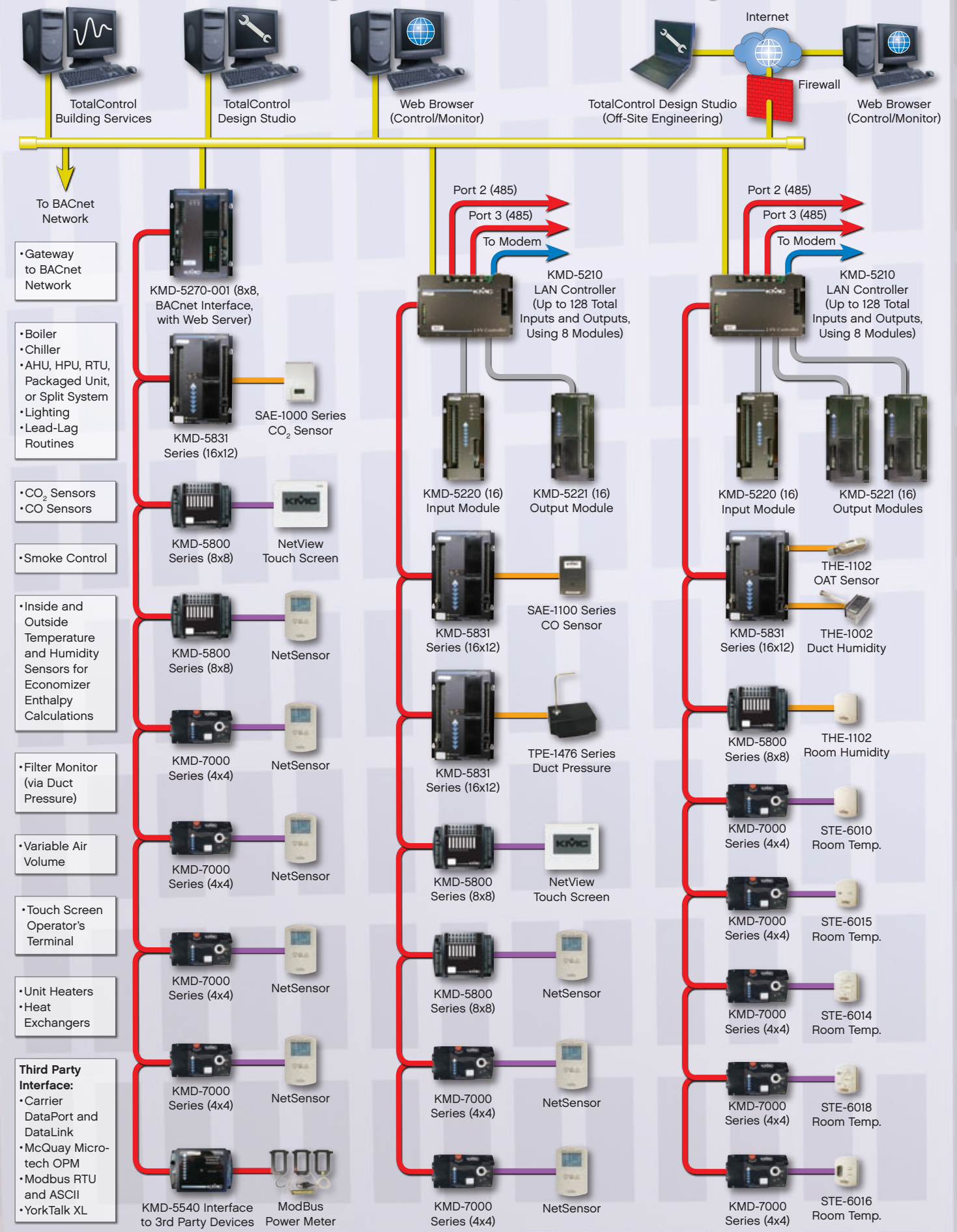

(Output devices not shown include actuators, valves, relays, triacs, and variable frequency drives. Configurations shown are only a few of many possible options.)